



Development and research of the properties of sealing grease for threaded connections of casing pipes

Oleh Martsynkiv

PhD in Technical Sciences, Associate Professor
Ivano-Frankivsk National Technical University of Oil and Gas
76019, 15 Karpatska Str., Ivano-Frankivsk, Ukraine
<https://orcid.org/0000-0003-4583-5944>

Ivan Vytvytskyi

PhD in Technical Sciences, Associate Professor
Ivano-Frankivsk National Technical University of Oil and Gas
76019, 15 Karpatska Str., Ivano-Frankivsk, Ukraine
<https://orcid.org/0000-0003-3782-3695>

Igor Paliichuk

PhD in Technical Sciences, Associate Professor
Ivano-Frankivsk National Technical University of Oil and Gas
76019, 15 Karpatska Str., Ivano-Frankivsk, Ukraine
<https://orcid.org/0000-0002-8443-2702>

Mykola Seniushkovych

PhD in Technical Sciences, Associate Professor
Ivano-Frankivsk National Technical University of Oil and Gas
76019, 15 Karpatska Str., Ivano-Frankivsk, Ukraine
<https://orcid.org/0009-0008-9943-869X>

Ivan Dudych*

PhD, Associate Professor
Ivano-Frankivsk National Technical University of Oil and Gas
76019, 15 Karpatska Str., Ivano-Frankivsk, Ukraine
<https://orcid.org/0000-0003-2917-0612>

Roman Luchynskyi

Postgraduate Student
Ivano-Frankivsk National Technical University of Oil and Gas
76019, 15 Karpatska Str., Ivano-Frankivsk, Ukraine
<https://orcid.org/0009-0003-1277-5487>

Abstract. The tightness of threaded connections in casing is a critical issue, as it directly affects the reliability of well casing and, consequently, their trouble-free and long-term operation. Given that the oil and gas industry is tasked with maximising the energy demand by its own production, this problem remains relevant. The aim of this study was to investigate the properties of a newly developed sealing grease for threaded connections in casing pipes and to confirm its effectiveness compared to other commercially available products. Analytical and experimental methods were used to conduct the research. Industrial material was analysed for the quality of well casing and it was revealed that numerous

Suggested Citation: Martsynkiv, O., Vytvytskyi, I., Paliichuk, I., Seniushkovych, M., Dudych, I., & Luchynskyi, R. (2025). Development and research of the properties of sealing grease for threaded connections of casing pipes. *Prospecting and Development of Oil and Gas Fields*, 25(1), 19-30. doi: 10.63341/pdogf/1.2025.19.

*Corresponding author



Copyright © The Author(s). This is an open access article distributed under the terms of the Creative Commons Attribution License 4.0 (<https://creativecommons.org/licenses/by/4.0/>)

wells exhibited defects in their casing associated with the leaks of threaded connections of casing pipes. The causes of threaded connection failure were classified and the main factors affecting their tightness were identified. A sealing grease was developed, consisting of carbamide resin, organophilic aerosil, graphite, fumed silica and ammonium chloride. The following indicators were determined to evaluate the effectiveness of the developed grease: friction coefficient on the steel-steel surface, adhesion strength, grease shear resistance, tightness of the threaded connection during internal pressure testing, and coefficient of performance. It was established that the proposed grease has a higher initial adhesion force than others, and it also increases steadily during the polymerisation process and reaches its maximum value after fifteen hours of curing; the grease has a lower coefficient of friction, higher shear resistance and a significantly higher efficiency factor. The studies confirmed an increase in the performance of threaded connections of casing pipes using the developed lubricant

Keywords: well casing; efficiency coefficient; reliability; sealing grease; adhesion force

Introduction

The problem of ensuring the tightness of threaded connections in casing pipes was regarded as one of the most pressing issues in the oil and gas industry. Leakage of these connections caused significant economic losses due to accidents, complications during drilling and operation of wells, and also had a negative impact on the environment. The main aspects of the issue were justified by the following aspects: high frequency of complications and significant negative consequences; the complexity of ensuring reliable tightness; the influence of a wide range of operational factors; the imperfection of existing designs and technologies; economic and environmental components.

The wells under construction at present were considered highly expensive engineering and technical structures designed for long-term operation. However, during the construction process, complications and accidents occurred, caused by a decrease in the performance of casing strings due to the loss of initial strength and tightness of their coupling joints. According to researchers N. Ji *et al.* (2023) and B. Yang *et al.* (2023), improving the reliability of casing strings is a prerequisite for increasing the efficiency and ensuring the safety of the operation of oil and gas wells constructed in difficult mining conditions, which requires improving their technical parameters, and this primarily concerns the threaded connections of pipes used for these strings. Scientists H. Xu *et al.* (2023) and B. Kim & J.-Y. Yoon (2024) noted that most often, coupling threaded connections were used to complete casing in industrial environments, which are subject to requirements not only for strength for various types of loads, but also for tightness. The thread profiles used in casing connections are inherently leaky due to their structural features.

In some threaded connection designs, such as trapezoidal threaded casing with increased tightness (TTC) and couplingless casing (CC), provide for sealing elements on the contacting surfaces, which, when screwed together properly, form an impermeable contact. According to V. Vasylyshyn *et al.* (2020), the manufacture of such connections requires high accuracy, precision equipment, which affects the cost of casing, and in some cases, even such connections do not provide the necessary wellbore fixing functions. According to the results of the research by Z. Xu *et al.* (2023) note that leaky threaded connections can be a result of deviations in the geometric parameters of

the thread from the requirements of the standard, namely: deviations in the profile of turns, pitch, taper and axial tension of the thread, which can lead to incomplete contact of surfaces and the formation of gaps. C. Blanc *et al.* (2019) argue that it is also important to avoid defects on the surface of the threads during threading (burrs, dents, scratches) and damage during transport.

Therefore, solving the problem of tightness of casing threaded joints will prevent interbedded cross flow, as casing strings are designed to isolate different geological horizons, thereby preventing uncontrolled movement of fluids (oil, gas, water) between them. Leaky joints can lead to contamination of productive formations, watering of wells, reduced production rates and loss of valuable resources. Tight casing joints ensure the integrity of the wellbore as they guarantee the strength and stability of the casing string under various types of loads (own weight, rock pressure, hydraulic pressure of liquids, temperature fluctuations).

Environmental protection, personnel and equipment safety are still important. Uncontrolled leakage of corrosive impurities that may be present in hydrocarbon fluids (hydrogen sulphide, carbon dioxide, sulphur) through leaky connections can lead to pollution of groundwater, soil and the atmosphere, causing significant damage to the ecosystem, and pose a threat to the life or health of personnel and damage to equipment. The aim of the study was to develop an effective sealing agent for threaded casing joints, to experimentally evaluate its properties, and to compare its main parameters with existing analogues. Based on the above, the following tasks were formulated to solve the problem of tightness of casing threaded joints: conducting analytical studies of leakage of casing threaded joints; identifying the main factors affecting such leakage; developing and substantiating the formulation of a sealing lubricant; determining its main properties; conducting experimental studies to assess the effectiveness of the lubricant compared to the analogues used.

Materials and Methods

The effectiveness of any sealing grease must be confirmed by the following requirements: maximum mobility, i.e. low viscosity, at the time of screwing the threaded connection to ensure that all gaps are filled with grease; minimum mobility (high viscosity) during the operation of threaded

connections; increased operating pressure and temperature limits (respectively 50-70 MPa at 200°C) while maintaining operational characteristics; pronounced structural properties and ability to resist shear. Taking into account the above requirements, a sealing grease for casing threaded connections was developed by scientists from the Department of Oil and Gas Well Drilling of the Ivano-Frankivsk National Technical University of Oil and Gas (US-OT) (Kotskulych & Tyshchenko, 2009).

The sealing grease consists of a carbamide resin binder, ammonium chloride hardener, as well as an organophilic aerosil and fumed silica, with the following ingredient ratios, %: organophilic aerosil – 4-6; graphite – 5-8; fumed silica – 0.5-1.0; ammonium chloride – 1-2; carbamide resin – the rest. The US-OT sealing grease is prepared according to the following procedure. A fumed silica is added to the calculated mass of the organophilic aerosil and mixed until a homogeneous state is obtained. Then the resulting mixture is injected into carbamide resin, graphite is added and mixed for 20-30 minutes. Before use, the required amount of hardener is added to the composition and mixed until a homogeneous mass is obtained. The grease can be polymerised at temperatures above 100°C without the addition of a thickener. Apply the grease to the surface with a paint brush in a uniform layer.

The quality of the sealing grease was assessed by the following indicators: friction coefficient (affects the value of the screwing torque), adhesion force (characterises the strength of adhesion of the lubricant to metal thread surfaces), shear resistance of the lubricant (to assess the viscosity characteristics of the lubricant), tightness of the threaded connection (determines the resistance of the lubricant to extrusion from the thread gap under high pressure), and lubricant efficiency factor. Similar studies were conducted using USSA and R-2 MVP greases to compare the performance indicators. As of 2025, they are produced in accordance with GOST 3333-80 (1980) outside Ukraine. The manufacturer of these lubricants is Expert-oil. All of the above indicators were determined by the experimental method using the instruments available at the Department of Oil and Gas Well Drilling, except for the lubricant efficiency factor, which was estimated by the analytical method using experimental data. In order to analyse the technical condition of production and intermediate casing strings, there were considered cases of leakage at the fields of the Shebelynka Drilling Department (SDD), in particular, at such sites as Yulivske, Muratovske, Zakhidno-Shebelynske and Lychkivske.

The adhesion force was measured by the method of determining the force of separation of a metal disc that interacted with a metal plate through the lubricant after contact for one minute. The change in the adhesive properties of the lubricants over time was also measured. The coefficient of friction was measured using the PT-2 device. This device was developed at the Department of Oil and Gas Well Drilling at the Ivano-Frankivsk Institute of Oil and Gas on the basis of the widely used SNS-2 device in the 1980s. It was designed to determine the coefficient of friction of

various materials. The shear resistance of the lubricant was assessed using the simplest method – forcing the lubricant through the holes in the container and matrix using the C-2 device (Fig. 1).

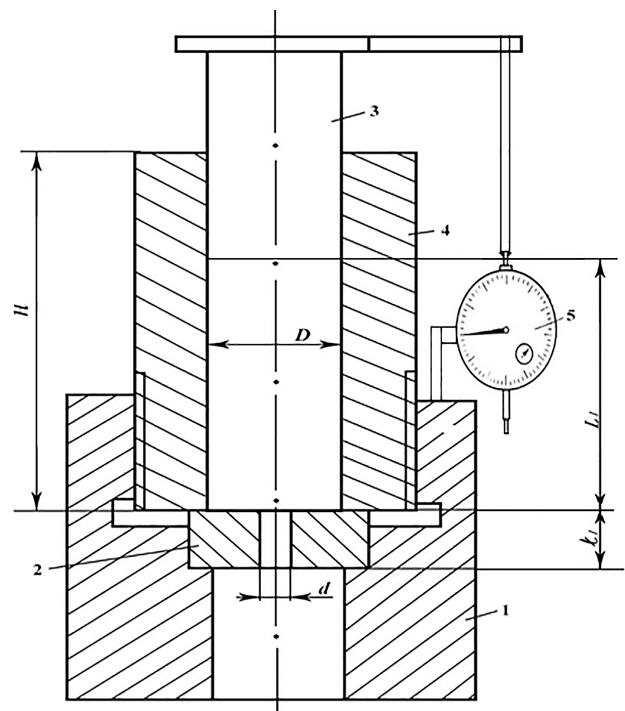

Figure 1. Device for determining the shear strength of grease

Note: 1 – body; 2 – matrix; 3 – punch; 4 – container; 5 – clock-type indicator; D – diameter of the container hole; d – diameter of the matrix hole; the thickness of the matrix is selected from the condition of filling the container with lubricant

Source: developed by the authors

The procedure for evaluating the shear resistance of the grease was as follows. The container of the device was filled with sealing grease, after which a compressive load was applied to the punch and the moment of grease pushing through the hole of the die was recorded according to the readings of the clock-type indicator. The value of the shear resistance of the grease (τ_m) was determined by the formula:

$$\tau_m = \frac{P}{F_m}, \quad (1)$$

where P – the compressive load applied to the punch of the device, at which the lubricant displacement begins, N; F_m – the surface area of the hole in the matrix, m².

The quality of sealing greases for threaded connections was evaluated by the efficiency factor (k_{ef}). To assess it, the casing was screwed together with the application of different types of lubricants to the threaded connections, aged for 15 hours, and then pressurised with the creation of internal overpressure to check the tightness of the connections. It was determined by the formula:

$$k_{ef} = \frac{P_n}{P} \times \frac{l_n}{l}, \quad (2)$$

where P – the critical pressure at which the tightness of a threaded connection screwed without lubrication occurs, MPa; i_s – the dry friction coefficient; P_n – the critical pressure at which tightness of a threaded connection screwed with lubrication occurs, or the maximum allowable pressure for the casing if the tightness of the connection is not failed, MPa; i – is the friction coefficient in the presence of lubrication.

Results and Discussion

Complications and accidents during the construction and operation of oil and gas wells, such as pipe separation at coupling joints or falling pipe sections, are often the result of difficult mining and geological conditions in the casing. This can lead to inter casing pressures and

interstitial flows, as well as complications during casing cementing and well operations. Various complications arise as a result of threaded casing connections being depressurised, the most difficult of which is inter casing pressure (ICP). Failure of standard threaded connections is responsible for 70% of all casing-related complications (Kotskulych, 2007). The negative consequence of such complications is a decrease in well production rate, material losses, and damage to subsoil and the environment. Due to the high permeability of gas, the loss of well casing tightness in the process of gas field development is the most dangerous. An analysis of industrial materials and literature on the issue of leakage of pipe threaded connections allowed developing a qualification of the causes of these violations (Table 1).

Table 1. Classification of causes of threaded joints leakage

Incorrect strength calculation of the columns	Violation of casing assembly technology	Wear of casing strings
<ol style="list-style-type: none"> 1. Incorrect consideration of internal overpressure during various operations in the casing. 2. Failure to take into account the increase in axial loads when the temperature changes, excessive external and internal pressures. 3. Failure to take into account the simultaneous action of internal pressure and tensile load. 	<ol style="list-style-type: none"> 1. Running pipes with defective threaded connections. 2. Mismatch of thread type and lubricant to well conditions. 3. Creating an internal pressure that exceeds the permissible one. 4. Poor connection of column sections. 5. Lack of control over torque values when screwing threaded connections. 6. Incorrect seating of the pipe in the coupling when screwing them together. 7. Uncontrolled screwing speed. 8. Mismatch of temperature conditions. 9. Damage to the thread. 10. Incorrect scheme of applying forces to the pipe. 	<ol style="list-style-type: none"> 1. Wear and tear of drill pipes and locks. 2. Wear and tear of bits and catching tools. 3. Corrosion. 4. Hydroabrasive wear.

Source: developed by the authors

The reasons for the loss of casing integrity at the Shebelynka SDD fields are presented in Table 2. The elimination of these complications and accidents requires significant funds, reduces the payback period, and causes large losses for the companies. Sometimes wells have to be abandoned due to casing accidents. The main causes of casing accidents are: incorrectly selected well design for the geological conditions of their construction; casing leaks due to damaged threaded connections. The required tightness of threaded connections can be achieved in the following ways: using different sealing materials; creating threaded connections with tightness units, or a simultaneous combination of both methods (Chernova & Kuntsiak, 2016). Coupling joints with leakage units, such

as TTC, are considered promising. However, deviations in the manufacture of such connections, which are allowed by DSTU 8932:2019 (2019), significantly reduce their reliability. The sealing of threaded connections is achieved by tightly fitting the threads on the sides of the profile after screwing the connections, but the screw channel between the tops and bottoms of the threads must be filled with sealant (Rymchuk *et al.*, 2019). In the case of high-performance sealants, the tightness of the pipe coupling joint can be increased to a pressure that corresponds to the strength of the pipe body. Thus, the tightness of casing threaded connections depends primarily on the size and shape of the screw channel and the properties of the sealant filling this channel.

Table 2. Leakage of casing strings at Shebelynka SDD fields

Area, field	No. of a well	Production casing diameter, m	Well purpose	Causes of leakage
Yulivske	25	0.146	exploratory	Screwing of threaded connections with low torque values
Muratovske	51	0.146 × 0.168	operational	Use of low-performance lubricants. Screwing of threaded connections with low torque values
Zakhidno-Shebelynske	7	0.140 × 0.168	operational	Use of low-efficiency lubricants
Lychkivske	52	0.140 × 0.168	operational	Use of low-performance lubricants. Screwing threaded connections without torque control
Lychkivske	54	0.146 × 0.168	operational	Use of low-performance lubricants. Screwing threaded connections without torque control

Source: developed by the authors on the basis of industrial material

In addition, the following factors can be identified that affect the tightness of a tapered casing threaded connection accuracy of threading in the coupling and on the pipe; length of the working part of the thread; deviation of the angle of inclination of the threaded part, pitch, height of the thread profile; taper and ovality of pipes and couplings; value of axial tension of the thread when screwing; duration and nature of the load and pressure; viscosity of the pressure generating agent (liquid or gas) and the degree of its destructive effect on the sealant and thread metal. It was established that the efficiency of using the strength of casing material depends on the strength and tightness of threaded connections, which are determined by: the type of connection profile and precision of manufacturing of thread elements; type of sealant and its properties; value of screwing torque; value of axial tensile load; value of internal and external overpressure.

The results of research on the contact surface of the pipe and coupling of leaky threaded connections by V.Ya. Vasylyshyn *et al.* (2020) showed that when the permissible value of the screwing torque is exceeded, expansion (shearing, crushing) of one, two or more thread turns occurs on both the coupling and the pipe. Therefore, it can be concluded that such surface disturbances can cause not only liquid or gas leakage, but also a significant decrease in the tensile strength of threaded connections. To increase the tightness of the contact between the elements of threaded connections, various lubricants were used, including anaerobic sealants, the consistency of which should be sufficient to prevent their displacement from the gaps of the threaded connection (Femiak & Zelinskyi, 2024a; 2024b).

Researchers such as V. Vasylyshyn (2017) and Y. Mou *et al.* (2024) believe that the main cause of leakage of threaded connections is their under-seating due to incomplete selection of axial tension and insufficient screwing torque. The amount of torque depends to a greater extent on the size of the gaps in the thread, taper deviation, profile height, number of turns with an incomplete profile, etc. In addition, the grease that fills the gaps under pressure takes on part of the tensile load, reducing contact pressures on the contacting surface areas. Therefore, the main criteria for the correctness of screwing joints are the amount of tension and screwing torque, which requires the development of reliable control tools and technologies for their use. According to DSTU 8932:2019 (2019), the criterion for the tightness of threaded casing connections is to control the value of the conditional axial tension, the value of which is regulated by this standard when screwing elements both manually and using mechanical devices.

Pipes with a triangular thread profile: when hand screwing galvanised or phosphated couplings to pipes, the tension must be equal to A (distance from the end of the coupling to the end of the thread on the pipe when screwed together by hand). Maximum deviations are ± 3.2 mm. After screwing the pipe and the coupling on the machine, the end of the coupling must coincide with the end of the thread on the pipe. Maximum deviations are ± 3.2 mm. Casing pipes

with trapezoidal coupling threads (OTTM): when manually screwing the couplings with pipes, the tension should be (14 ± 3) mm. After screwing the pipe and the coupling on the machine, the end of the coupling should coincide with the end of the thread on the pipe or not reach it by no more than 5 mm. OTTG pipes: when screwing the couplings to the pipes by hand, the tension must be (10 ± 2) mm. After screwing the pipe and the coupling on the machine, the pipe end face and the coupling stop should be in contact along the entire perimeter of the joint of the stop surfaces. A gap of < 1 mm between the pipe and coupling bearing surfaces is permissible (for B pipes).

However, this criterion cannot be considered reliable, mainly due to deviations in the geometric parameters of the threads, uneven surface conditions, and different screwing conditions. Therefore, the main criterion for screwing should be the torque value, which is regulated depending on the strength group of the pipe material, wall thickness and pipe diameter. To ensure the tightness of threaded connections of casing pipes, the following requirements must be met during their manufacture the maximum total gap between the mating threads of the pipe and the coupling should not exceed 0.3 mm; the non-straightness of the cone formation should not exceed 0.04 mm; the coupling should be screwed onto the pipe in compliance with the torque values recommended by; threads on high-strength pipes should be cut on special machines; and high-performance sealants should be used.

To seal threaded connections, methods for applying a thin layer of sealing material to the thread surface were developed by Ukrainian scientists. The most reliable way was to apply a layer of soft metal (aluminium, zinc) inside the coupling by electrometallurgy (Kotskulych & Tyshchenko, 2009). This method also has significant disadvantages, such as the need for additional expensive equipment, energy and time consumption, and such metals often do not withstand corrosion from aggressive environments found in the subsoil.

According to ISO 13679:2019 (2019) and ISO 11960:2020 (2020), the main criterion for the quality of threaded casing connections is torque, which depends on the strength group of the steel, the diameter of the pipe and its wall thickness. The method of resealing the joints is widely used. The method is based on the use of a highly elastic compound. However, this method is ineffective due to significant drawbacks, namely: the need to create high internal pressure in the process of pressing the compound into the threaded connection, which can damage the pipe body; low adhesion of the highly elastic compound to the metal surface covered with a hydrocarbon film.

A method of sealing threaded connections using fluoroplastic sealing material (FUM tape) was also developed. The method is quite simple and relatively reliable; the fluoroplastic tape is non-toxic, plastic and has sufficiently high sealing properties. The disadvantage of this method is that when screwing threaded connections using FUM tape, there may be cases of loosening of the connection or even spontaneous loosening in the well, which

can lead to leakage of the connections. This is due to the low adhesion force of the fluoroplastic sealing material to the thread surface. Amoco (USA) successfully used cathodic protection, which reduces fluid flow through casing by 75% (Barrett & Taylor, 1976).

Patent No. 73192 (2005) proposes a method of cycling casing over the wellhead during casing run. In this case, the threaded connections are screwed with a regulated torque value, which is monitored using a torque meter, then, without removing the casing from the wedges, the threaded connection is loaded with an axial load equal to the weight of the casing. After that, the casing is unloaded onto the wedges again and screwed down with a regulated torque value. The load-tighten cycle is repeated until the connection no longer tightens after the next load. This method is very time-consuming, which may be unacceptable when fastening deep wells.

In industrial conditions, a method of tightening threaded connections of casing strings run into the well was tested, the essence of which is that a torque is applied to the casing string run into the well with a simultaneous increase in excessive external pressure. Increasing the pressure makes it possible to use torque transmission more efficiently, increase the tightness of threaded connections and thereby restore the casing string's tightness. However, this method is too complicated to implement and cannot be used after cementing the casing. O-rings made of elastic materials, such as fluoroplastic, were also used to seal the threaded connections of casing pipes. Hydraulic tests of threaded connections with fluoroplastic O-rings showed their high reliability, but there are cases when these rings were destroyed by friction during screwing.

The Hydril company (USA) developed recommendations for screwing and running casing into the well (TernarisHydril running manual, n.d.), which lists the following requirements to ensure tightness: the nipple should be inserted into the coupling sequentially and carefully so as not to damage the thread or screw it through the thread; the start of screwing should be slow until the first thread turns are engaged; if screwing is done without force, the speed can be increased; when mechanical wrenches are used, they should grip the pipe as close to the thread as possible to avoid distortion during screwing; when screwing, do not exceed the recommended torque values; during screwing, the pipe and the coupling should be heated gradually and evenly.

An important task was to choose the right sealing greases or special sealants that must meet certain requirements, in particular, withstand high pressures and temperatures, and aggressive environments (Xie, 2021; Xie *et al.*, 2021). This is a fairly simple and reliable way to achieve the required tightness of casing threaded connections, which consists in filling the structural and technologically necessary gaps with sealing materials (sealants), which also serve as a lubricant to facilitate the screwing process. The following requirements are imposed on such materials: the required consistency, sufficient to prevent the pressure of liquids or gas from removing it from the

thread gaps; consistency of properties over time and with temperature changes within a certain range; good lubricating properties; prevention of jamming when screwing threaded connections. The most important criterion is the required consistency of the material.

There are a number of such materials (mainly grease-based greases) that were used for screwing threaded connections of oil pipes. The most common graphite grease is USSA, which consists of 65% solidol and 35% silver graphite. P-2 MWP grease is based on 18.4% machine oil with 4.6% aluminium stearate, 14% silicone fluid No. 5, 18% graphite, 28% zinc and 17% copper. Graphite in these greases acts as an anti-friction material. Graphite properties are unchanged at high temperatures (200-2,000°C). The disadvantage of graphite greases is that the permissible specific pressure for it should not exceed 3-4 MPa. Higher pressures cause the destruction of the graphite film, which causes seizure when screwing threaded connections. These lubricants are used in wells with an internal pressure in the casing string of no more than 13 MPa.

Studies conducted at the Ukrainian Research Institute of Natural Gases showed that polymer alloys based on epoxy resins, in particular, the US-1 sealing grease, have the necessary sealing qualities, strength, elasticity and resistance to loads, as well as chemical stability to hydrocarbons. Its composition includes the following components: K-153 compound, which is ED-5 resin plasticised with MGF-9 polyester and thionol; hardener – cubic hexamethylene diamine residue; fillers used to enhance sealing properties and reduce friction forces that occur when fastening joints. US-1 has a high sealing capacity (up to 50 MPa). Disadvantages of US-1 are: toxicity, which worsens sanitary and hygienic working conditions and pollutes the environment; rapid precipitation of metal fillers (powders and powders); increase in pipe screwing torque (by 40-60%); rapid curing (application time of about 1.5 hours); difficulty of use at temperatures above +10°C (the need to heat the lubricant and the threaded end of the pipe), inseparability of the joint (after the lubricant hardened, the joint must be heated to a temperature of 300°C to unscrew it).

Synthetic lubricants were also used to ensure the tightness of threaded connections. The developed synthetic threaded joint lubricant was designed to improve the tightness and corrosion and fatigue resistance of threaded joints of oilfield tubular goods and downhole motors. Synthetic sealing grease (SG-1) was made on the basis of alkyl alkylresorcinol epoxyphenolic resin with fillers. This grease has high adhesion, helps to effectively protect threads from corrosive substances, and increases wear resistance during repeated screwing and loosening. The disadvantages of this grease are: it cannot be used at temperatures below -40°C and above +100°C; when used, it is necessary to carefully prepare the threaded connections; very high viscosity (before applying to threaded connections, it requires dilution with oil). Table 3 provides recommendations for the use of sealing materials for casing in different types of wells.

Table 3. Types of sealing materials for casing in different types of wells

Well type	Thread	Lubricant	Temperature application, °C	Permissible internal pressure, MPa
Oil	Triangular	P-2 MVP	-5 ± 100	12.7
	Triangular	US-1	0 ± 120	22.4
	Triangular	P-402	-50 ± 200	16.2
	Triangular	FUM tape	-20 ± 200	18.9
Gas, gas condensate	TTC, CC	P-2 MVP	-5 ± 100	23.1
	Any	US-1	0 ± 120	25.7
	TTC, CC	P-402	-50 ± 200	17.5
	Any	FUM tape	-20 ± 200	24.6

Source: developed by the authors based on Y. Kotskulych & O. Tyshchenko (2009)

Bestolife produces a sealing grease for threaded connections consisting of synthetic and amorphous graphite and non-metallic additives (Bestolife® metal free, n.d.). The temperature resistance of the grease is over 200°C. Shell silicone thread lubricants are used to seal threaded connections. These lubricants are a mixture of metal and graphite powders evenly distributed in a silicone base with a mass fraction of 36%. The solid components of the grease, which have a mass composition of 25%, are a mixture of graphite and lead powders and zinc dust. The basis of the modified thread grease is a lubricant mixture that, in

combination with powdered metals and graphite, increases the tightness of threaded connections under various operating conditions. The above-mentioned greases are manufactured outside Ukraine and require significant funds, so an alternative analogue of the sealing grease was developed. The characteristics of the components of the developed grease are given below. Carbamide resin of the KF-MT-D or KF-MT-F grades is a homogeneous suspension of white to light yellow colour, free of impurities, non-flammable and non-explosive. The physical and chemical properties of carbamide resins are shown in Table 4.

Table 4. Physical and chemical properties of carbamide resins

Name of property (constant) and unit of measurement	Physical value with maximum deviations	
	KF-MT-D	KF-MT-F
1. Appearance	Homogeneous suspension from white to light yellow colour without foreign inclusions	
2. Mass fraction of dry residue, %	61 ± 1	66 ± 2
3. Mass fraction of free formaldehyde in 24 hours after manufacture, % not more than	0.15	0.15
4. Conditional viscosity (at 20 ± 0.5°C) according to the viscometer VZ-246, with a nozzle diameter 4 mm, s	50-90	80-100
5. Concentration of hydrogen ions, pH	7.5-8.5	7.5-8.5
6. Gelatinisation time: at 100°C, s	50-70	50-70
7. Maximum miscibility of the resin with water (at 20 ± 1°C) in the ratio by volume, not less than	1:1-1:2	1:2-1:4
8. Density, kg/m ³	1,260 ± 0.005	1,270 ± 0.005

Source: developed by the authors on the basis of TU U 24.1-32358806-005:2009 (2009)

The organophilic aerosil changes the volumetric and mechanical properties of the grease, significantly increasing its hydrophobicity and the strength of molecular interaction

between the grease and the metal surface of the thread. The grease contains organophilic aerosil of AM-200, AM-300 or AM-380 grades, which have the properties shown in Table 5.

Table 5. Physical and chemical properties of organophilic aerosil

Indicators	Aerosil brand		
	AM-200	AM-300	AM-380
1. Appearance	White loose powder		
2. Specific surface, m ² /kg	200 ± 25	300 ± 30	380 ± 30
3. pH of aqueous suspension, not less than	3.6-4.3	3.6-4.3	3.6-4.3
4. Bulk density, g/l, uncompressed/pressed	60/120	60/120	60/120
5. Moisture content, % (dried at 105°C)	-	1.5	1.5
6. Hydrophobicity, %, not less than	90.0	98.0	99.0
7. Average particle size, µm	12	7	7
8. Mass fraction of SiO ₂ in terms of hardened substance, %, not less than	99.9	99.9	99.9
Porosity	Porous		

Source: compiled by the authors based on I. Pertsev (2010)

Graphite was added to give the lubricant extreme pressure properties. White spirit, acetone, petrol or diesel fuel was used as a humectant for the aerosil. The humidifier ensures the uniform introduction of hydrophobic organophilic aerosol into the liquid carbamide resin and increases the frost resistance of the grease. Ammonium chloride ensures polymerisation of the grease in a screwed threaded connection within 6-12 hours. All components of the grease were produced in Ukraine and are safe in terms of harmful effects on personnel and the environment.

The above properties of the developed grease and some well-known and practically used greases were determined in the course of the study. The most important parameter was the adhesion force, which characterised the ability of the grease to adhere to the thread surface and increase this value over time. Based on the results of the study of the adhesion force, a graph was constructed (Fig. 2), which shows that immediately after applying the lubricant to the surface of the metal disc, the adhesion force is low.

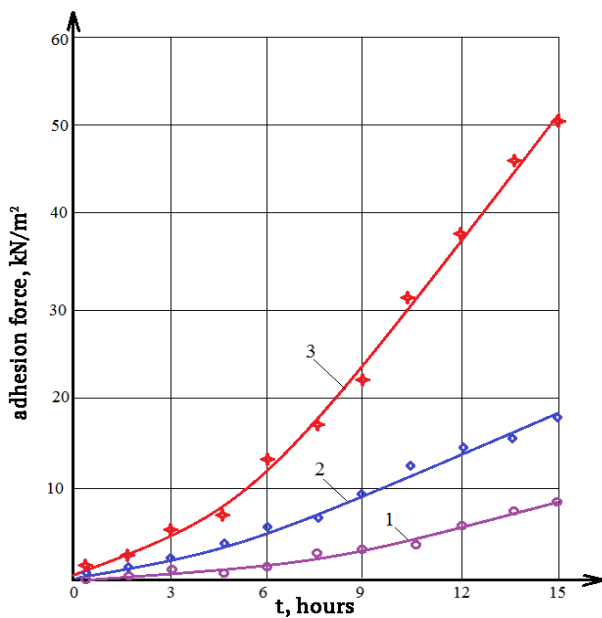

Figure 2. Changes in the adhesive properties of sealing greases over time

Note: 1 – USSA grease; 2 – R-2 MVP grease; 3 – US-OT grease
Source: developed by the authors

This is important for the process of casing screwing, since the adhesion force affects the torque value, which should be applied only to select the radial tension of the threaded connection. The maximum time for testing the adhesion force was chosen to be commensurate with the average time of casing run into the well, since at the end of this process, i.e. before cementing, the casing must be sealed to ensure the formation of a high-quality fastening. Over time, the adhesion strength of all the tested lubricants increases, but with varying intensity. After six hours from the start of applying the greases to the metal disc, the developed grease begins to intensively increase the adhesion force due to the polymerisation reaction and reaches its maximum value (more than 50 kN/m²) after 15 hours of curing, which is 2.9 times higher than the P-2MVP grease and 5.7 times higher than the USSA grease. The ability of the lubricant to resist its displacement from the technological gaps of the threaded connection also depends on the value of the adhesion force, which is confirmed by the results of the studies presented in C. Teodoriu *et al.* (2020). These studies concern the tightness of Oil Country Tubular Goods (OCTG) threaded connections using five different types of compounds and a programmable digital rheometer under the influence of shear rate, temperature, and various loading conditions. The experimental results showed that the low viscosity properties of the compounds did not ensure the tightness of the threaded connections and also had low heat resistance (some samples lost their sealing ability at 70°C). Carbamide resin, which is the basis of the grease developed by the authors, has a higher temperature resistance (150-170°C) and the gelatinisation time at 100°C is 50-70 s, meaning that the grease quickly gains consistency and is retained on the thread surface.

Another important parameter that determines the amount of torque for screwing casing threaded connections is the friction coefficient. Its value is influenced by the ability of the lubricant to fill in the irregularities of rough thread surfaces, minimise the friction force during screwing of threaded elements and provide anti-seize protection. The results of the tests are presented in Table 6, from which it can be concluded that the coefficient of friction of a steel-steel pair using US-OT grease is on average 64% lower than that of other greases.

Table 6. Results of the grease study

Grease name	Lubricant adhesion, kN/m ²	Shear resistance of the grease, MPa	Lubricant friction coefficient	Lubricant efficiency factor
USSA	4.75	0.124	0.088	1.41
R-2 MVP	2.47	0.135	0.069	2.01
US-OT	7.02	0.145	0.046	3.4

Source: developed by the authors

The relevance of this parameter is confirmed by the results of studies of the physicochemical and tribological properties of anti-seize thread lubricant presented in W. Zhimin *et al.* (2021). The composition of the extreme pressure grease includes base oil, di-aromatics and graphite

powder mixed with a viscosity index improver, antioxidant and rheological additive. Thermal stability, anti-wear and antifriction properties were studied, but there is no information on its sealing ability. In the absence of lubrication, the phenomenon of local welding and diffusion may also

occur on the screwed surfaces due to high contact pressures, as noted in the work of K.K. Kakulite & B. Kandasubramanian (2019). To avoid this negative phenomenon, it was proposed to use solid lubricants, hard ceramic coatings such as titanium nitride, and synergistic coatings of copper or silver based on PTFE. However, in the opinion of the authors of the current study, such solutions are difficult to implement and use in comparison with the application of grease lubricants to the threaded connection.

The required service life of the casing threaded connection also depends on the corrosion processes occurring on the metal surface under the influence of aggressive media occurring in the subsoil (e.g. hydrogen sulfide, carbon dioxide, acidic water, magnesium salts). Therefore, its protection from contact with aggressive environments is also important and should be counteracted by any anti-corrosion coating, including lubricants. In the work of D. Ernens *et al.* (2019) confirmed the need for phosphate-conversion coating of the surface of casing threaded connections and the application of grease lubricants to prevent corrosion processes and reduce friction forces during screwing. The developed US-OT grease has the necessary hydrophobic properties to protect the threaded connection from formation water, but additional research is needed to assess its resistance to other types of aggressive media.

In the process of running and cementing casing strings, the dispersed medium of the flushing fluid or cement mortar under pressure can cause the lubricant to be displaced from the technological gaps of the threaded connection. The ability of the lubricant to counteract this negative phenomenon is characterised by the shear resistance of the lubricant, in other words, its ability or the contact between it and the surfaces of the screwed elements to resist the mutual displacement (sliding) of the layers under the action of tangential (shear) stresses arising from any external force. The results of the study of the shear resistance of various greases are presented in Table 6, which shows that the highest value of this parameter is characteristic of the proposed grease, and accordingly, it has the highest resistance to extrusion from the technological gaps of the threaded connection during the curing process. The developed grease is recommended to improve the tightness of all types of casing threaded connections regardless of their design, since technological gaps are a potential channel for fluid penetration during well operation. The study by H. Xu *et al.* (2023) investigated the permeability of premium casing threaded connections with metal-to-metal sealing elements and confirmed the need to use sealing lubricants despite the presence of a sealing assembly.

The efficiency of screwing casing threaded connections depends on the composition of the lubricant, especially the presence of solid particles (e.g., particles of any metal), which increase the coefficient of friction and can damage the rubbing surfaces during screwing, as noted in K. Inose *et al.* (2016). This statement is consistent with the authors' research, since the developed formulation does not contain any solid particles, which has a positive effect on the screwing process. In general, the quality of

sealing greases for threaded connections was assessed using a complex parameter called the efficiency factor. It describes the ability of the lubricant to provide low values of the friction coefficient when screwing a threaded connection and its tightness under internal pressure. An example of calculating the effectiveness of US-OT lubricant for a casing pipe of the OTTM type -146 × 7.7 D. The value of the internal pressure at which the stresses in the pipe body reach the yield strength of 35 MPa. The leakage of the threaded connection without the use of lubricants was observed at a pressure of 26.3 MPa. When USSA grease was applied to the threaded connection, the leakage occurred at a pressure of 28.04 MPa. Then the efficiency factor is equal to:

$$k_{ef} = \frac{28.04}{26.3} \times \frac{0.117}{0.088} = 1.41. \quad (3)$$

When applying P-2 MVP grease to a threaded connection, a leakage occurred at a pressure of 31.2 MPa, and the efficiency factor is equal to:

$$k_{ef} = \frac{31.2}{26.3} \times \frac{0.117}{0.069} = 2.01. \quad (4)$$

With the use of US-OT grease, no leakage was observed, so $P_n = 35$ MPa, and the efficiency factor is equal to:

$$k_{ef} = \frac{35}{26.3} \times \frac{0.117}{0.046} = 3.4. \quad (5)$$

The results of the study of the properties of different lubricants are presented in Table 6. The data obtained are also consistent with the conclusions presented by B. Yang *et al.* (2023) and F. Ye *et al.* (2023), who presented the results of testing the tightness of casing after sealing threaded connections with lubricants and noted that the consistency of the lubricant and the magnitude of the pressure gradient are crucial for maintaining tightness. The study of the sealing properties of lubricants for casing threaded connections is key to ensuring well reliability, as they not only reduce friction during screwing, but also play a critical role in sealing gaps and preventing the flow of formation fluids. The analysis of the current state of the art in the use of sealing lubricants shows that work on the development of sealing lubricants remains relevant.

Conclusions

The results of the experimental work showed that the formulation of the developed US-OT grease, which consists of Ukrainian components and does not contain harmful substances, is compliant with the formulation of the developed grease, as well as its high efficiency in ensuring the tightness of threaded connections of casing pipes intended for oil and gas wells. The article highlights the results of the analysis of the main properties of the developed grease, including adhesion strength, shear resistance and friction coefficient. The grease is recommended for use with all types of casing connections, regardless of their design features, the presence of auxiliary sealing units and the type of coating applied to the threads. This is based on the

grease's ability to optimise the screwing process, fill technological gaps in the joint and, after the polymerisation reaction is complete, ensure its reliable sealing.

The qualitative characteristics of the grease were evaluated using the efficiency coefficient, the growth of which correlates with an increase in the degree of compliance of the grease with the stated requirements. Over time, there is an increase in the adhesive properties and shear resistance of the sealing grease; the cured material acquires hydrophobic characteristics, and the threaded connection of the casing demonstrates tightness at pressures that meet the maximum permissible values. The lubricant is compatible with the materials in contact, has no corrosive effect on casing and sealing elements and is safe for personnel.

Future research will be aimed at analysing the functionality of the lubricant in conditions that simulate the operation of deep wells, in particular in the presence of aggressive chemical environments (such as hydrogen sulfide, carbon dioxide, highly mineralised formation

water, chemogenic deposits) and under the influence of high temperatures and pressures. Since there is a growing demand for the creation of environmentally friendly lubricants (metal-free, biodegradable), the use of nanoparticles in lubricants to improve their properties, modern methods such as scanning electron microscopy for analysing thread damage; thermogravimetric analysis (TGA) and differential scanning calorimetry (DSC) for assessing the thermal oxidative stability of lubricants should be used for further research.

Acknowledgements

None.

Funding

None.

Conflict of Interest

None.

References

- [1] Barrett, S.L., & Taylor, J.M. (1976). Cathodic protection experience in Cook Inlet, Alaska. In *Offshore technology conference* (article number OTC-2700-MS). Houston: SPE. doi: 10.4043/2700-MS.
- [2] Bestolife® metal free. (n.d.). Retrieved from <https://bestolife.com/products/bestolife-metal-free>.
- [3] Blanc, C., Lewis, J., Ichim, A., Mutis, D., Zestran, A., Lucca, C.I., & Perello, L. (2019). New OCTG developments to overcome challenges in unconventional plays. In *SPE eastern regional meeting* (article number SPE-196596-MS). Charleston: SPE. doi: 10.2118/196596-MS.
- [4] Chernova, M., & Kuntsiak, Y. (2016). [Provision the tightness of casing strings due to the design features of threaded connections](#). *Rock Destruction and Metal-Working Tools – Techniques and Technology of the Tool Production and Applications*, 19, 86-92.
- [5] DSTU 8932:2019. (2019). *Casing pipes and couplings for them, technical requirements*. Retrieved from https://online.budstandart.com/ua/catalog/doc-page?id_doc=86378.
- [6] Ernens, D., van Riet, E.J., de Rooij, M.B., Pasaribu, H.R., van Haaften, W.M., & Schipper, D.J. (2019). The role of phosphate-conversion coatings in the makeup and sealing ability of casing connections. *SPE Drilling & Completion*, 34(1), 60-70. doi: 10.2118/184690-pa.
- [7] Femiak, Y., & Zelinskiy, A.A. (2024a). [Ensuring the tightness of casing in gas wells by using anaerobic sealants](#). In *The 3rd international scientific and practical conference "Perspectives of contemporary science: Theory and practice"* (pp. 518-521). Lviv: Scientific Publishing Center "Sci-conf.com.ua".
- [8] Femiak, Y., & Zelinskiy, A.A. (2024b). [Improving the tightness of casing strings in gas wells using anaerobic sealants](#). In *Scientific research and innovation: Proceedings of the 3rd international scientific and practical internet conference* (pp. 206-207). Dnipro: FOP Marenichenko V.V.
- [9] GOST 3333-80. (1980). *Graphite grease. Technical conditions. With amendments No. 1, 2, 3*. Retrieved from https://online.budstandart.com/ua/catalog/doc-page.html?id_doc=73383.
- [10] Inose, K., Sugino, M., & Goto, K. (2016). Influence of grease on high-pressure gas tightness by metal-to-metal seals of premium threaded connections. *Tribology Online*, 11(2), 227-234. doi: 10.2474/trol.11.227.
- [11] ISO 11960:2020. (2020). *Petroleum and natural gas industries – steel pipes for use as casing or tubing for wells*. Retrieved from <https://www.iso.org/standard/75278.html>.
- [12] ISO 13679:2019. (2019). *Petroleum and natural gas industries – procedures for testing casing and tubing connections*. Retrieved from <https://www.iso.org/obp/ui/#iso:std:iso:13679:ed-2:v1:en>.
- [13] Ji, N., Wang, P., Xie, J., Zhao, M., Feng, C., & Xie, J. (2023). Small-scale experimental research on the key parameters affecting metal-to-metal sealability. *Journal of Physics: Conference Series*, 2610(1), article number 012034. doi: 10.1088/1742-6596/2610/1/012034.
- [14] Kakulite, K.K., & Kandasubramanian, B. (2019). Rudiment of "Galling: Tribological phenomenon" for engineering components in aggregate with the advancement in functioning of the anti-galling coatings. *Surfaces and Interfaces*, 17, article number 100383. doi: 10.1016/j.surfin.2019.100383.
- [15] Kim, B., & Yoon, J.-Y. (2024). Design optimization of buttress type premium casing connection by modifying lower corner radius of stab flank. *Scientific Reports*, 14(1), article number 8018. doi: 10.1038/s41598-024-58881-3.

- [16] Kotskulych, Y. (2007). [Current state and prospects and prospects for improving the reliability of well fastening](#). *Oil and Gas Industry*, 5, 22-24.
- [17] Kotskulych, Y., & Tyshchenko, O. (2009). *Well completion*. Kyiv: Interpress LTD.
- [18] Mou, Y., Xie, Y., Wei, F., Zhao, H., & Han, L. (2024). Research on thread seal failure mechanism of casing hanger in shale gas wells and prevention measures. *Processes*, 12(6), article number 1253. doi: 10.3390/pr12061253.
- [19] Patent No. 73192. (2005). *Tubular threaded joint with reinforced stop*. Retrieved from <https://sis.nipo.gov.ua/uk/search/detail/385777/>.
- [20] Pertsev, I. (2010). *Aerosil*. Retrieved from <https://www.pharmencyclopedia.com.ua/article/2648/aerosil>.
- [21] Rymchuk, D.V., Kushch, A.I., & Dragomyretskiy, V.O. (2019). Growth of hermeticity of oil and gas wells. *Integrated Technologies and Energy Saving*, 2, 38-46. doi: 10.20998/%25x.
- [22] TenarisHydril running manual. (n.d.). Retrieved from <https://www.tenaris.com/en/products-and-services/octg/tenarishydril-running-manual/>.
- [23] Teodoriu, C., Bello, O., & Rinne, J. (2020). Experimental investigations of thread compounds viscosity degradation towards long term threaded connections leak resistance. *Journal of Natural Gas Science and Engineering*, 84, article number 103677. doi: 10.1016/j.jngse.2020.103677.
- [24] TU U 24.1-32358806-005:2009. (2009). *Carbamide-formaldehyde resins*. Retrieved from <http://www.ostchem.com/uk/o-kompanii/proizvodstvo/stirol>.
- [25] Vasylyshyn, V. (2017). [Ways to improve the reliability and tightness of casing strings](#). *International Scientific Journal "Internauka"*, 2(24), 134-135.
- [26] Vasylyshyn, V.Ya., Vasylyshyn, Ya.V., & Chorna, Yu.V. (2020). Improved coupling and pump connection pipes. *Scientific Notes of the Taurida National University Named After V. I. Vernadsky. Series: Technical Sciences*, 2(1), 67-70. doi: 10.32838/2663-5941/2020.1-2/12.
- [27] Xie, J. (2021). Considerations for analytical qualification of tubular connections for thermal and HPHT wells. In *SPE 2021 symposium compilation* (article number SPE-208439-MS). Virtual: SPE. doi: 10.2118/208439-ms.
- [28] Xie, J., Friesen, D., Droessler, M., Roth, T., & Xie, J. (2021). Experimental study for establishing metal-to-metal seal evaluation criteria for tubular connections in thermal and HPHT applications. In *SPE 2021 symposium compilation* (article number SPE-208438-MS). Virtual: SPE. doi: 10.2118/208438-ms.
- [29] Xu, H., Zhang, Z., Xiang, S., Yang, B., & Shi, T. (2023). Leakage model of tubing and casing premium connection based on sinusoidal contact simulation between rough surfaces. *Processes*, 11(2), article number 570. doi: 10.3390/pr11020570.
- [30] Xu, Z., An, C., Xie, Z., Zhang, J., Lim, F., & Zhang, Y. (2023). Full-scale resonant bending fatigue testing of casing joints under bending moment load. *International Journal of Pressure Vessels and Piping*, 207, article number 105105. doi: 10.1016/j.ijpvp.2023.105105.
- [31] Yang, B., Xu, H., Xiang, S., Zhang, Z., Su, K., & Yang, Y. (2023). Effects of make-up torque on the sealability of sphere-type premium connection for tubing and casing strings. *Processes*, 11(1), article number 256. doi: 10.3390/pr11010256.
- [32] Ye, F., Chen, F., Wang, W., Zhang, R., Zhou, X., Qin, K., & Di, Q. (2023). Flow in microchannels between sealing surfaces of casing connections: LBM simulation. *Geofluids*, 1, article number 5293830 doi: 10.1155/2023/5293830.
- [33] Zhimin, W., Shuo, X., Xiaoqiang, L., Yichen, B., Xiuqiang, S., & Yan, H. (2021). [Physicochemical and tribological properties of anti-seize thread lubricant](#). *China Petroleum Processing and Petrochemical Technology*, 23(4), 95-104.

Розробка та дослідження властивостей герметизуючого мастила для різьбових з'єднань обсадних труб

Олег Марцинків

Кандидат технічних наук, доцент
Івано-Франківський національний технічний університет нафти і газу
76019, вул. Карпатська, 15, м. Івано-Франківськ, Україна
<https://orcid.org/0000-0003-4583-5944>

Іван Витвицький

Кандидат технічних наук, доцент
Івано-Франківський національний технічний університет нафти і газу
76019, вул. Карпатська, 15, м. Івано-Франківськ, Україна
<https://orcid.org/0000-0003-3782-3695>

Ігор Палійчук

Кандидат технічних наук, доцент
Івано-Франківський національний технічний університет нафти і газу
76019, вул. Карпатська, 15, м. Івано-Франківськ, Україна
<https://orcid.org/0000-0002-8443-2702>

Микола Сенюшкович

Кандидат технічних наук, доцент
Івано-Франківський національний технічний університет нафти і газу
76019, вул. Карпатська, 15, м. Івано-Франківськ, Україна
<https://orcid.org/0009-0008-9943-869X>

Іван Дудич

Доктор філософії, доцент
Івано-Франківський національний технічний університет нафти і газу
76019, вул. Карпатська, 15, м. Івано-Франківськ, Україна
<https://orcid.org/0000-0003-2917-0612>

Роман Лучинський

Аспірант
Івано-Франківський національний технічний університет нафти і газу
76019, вул. Карпатська, 15, м. Івано-Франківськ, Україна
<https://orcid.org/0009-0003-1277-5487>

Анотація. Герметичність різьбових з'єднань обсадних колон є критично важливою проблемою, оскільки вона безпосередньо впливає на надійність кріплення свердловин, а відтак на їхню безаварійну та тривалу експлуатацію. Зважаючи на те, що перед нафтогазовою галуззю поставлено завдання максимального забезпечення потреби енергоносіїв власним видобутком, зазначена проблема залишається актуальною. Метою роботи було дослідити властивості розробленого герметизуючого мастила для різьбових з'єднань обсадних труб та підтвердити його ефективність порівняно з іншими використовуваними засобами. Для проведення досліджень у роботі використано аналітичний та експериментальний методи. Проаналізовано промисловий матеріал з якості кріплення свердловин та встановлено, що в багатьох свердловинах наявні дефекти у їхньому кріпленні, котрі пов'язані з негерметичністю різьбових з'єднань обсадних труб. Проведена класифікація причин порушень працездатності різьбових з'єднань та виділено основні чинники, що впливають на їхню герметичність. Розроблено герметизуюче мастило, що складається з карбамідної смоли, органофільного аеросилу, графіту, зволожувача аеросилу та хлористого амонію. Для оцінювання ефективності розробленого мастила було визначено такі показники: коефіцієнт тертя на поверхні пари «сталь-сталь», сила адгезії, опір мастила на зсув, герметичність різьбового з'єднання у процесі його опресування внутрішнім тиском та коефіцієнт ефективності. Встановлено, що запропоноване мастило має вищу початкову силу адгезії, порівняно з іншими, і до того ж вона постійно зростає у процесі полімеризації та досягає максимальної величини через п'ятнадцять годин тверднення; мастило має менший коефіцієнт тертя, більший опір на зсув та значно вищий коефіцієнт ефективності. Проведеними дослідженнями підтверджено підвищення працездатності різьбових з'єднань обсадних труб із використанням розробленого мастила

Ключові слова: кріплення свердловин; коефіцієнт ефективності; надійність; ущільнююче мастило; сила адгезії